



FOTON M-400

4x2 Rigid | 137 ps | 10.25 Ton GVW

Best Fuel Consumption With Turbo Power



EURO III

Pneumatic Brakes

2 YEAR WARRANTY / 70,000KM

- PERKINS ENGINE
- TURBO INTER COOLER
- EURO II

FOTON M-400



MASTER MOTOR COMPANY





FOTON M-400

4x2 Rigid | 137 ps | 10.25 Ton GVW

KEY FEATURES



Perkins Engine with TURBO INTER COOLER
• Powerful • Economical
• Large Torque (Low Speed)



Power steering with telescopic & tilt steering column



Tilt cabin with attractive dash board & folding seats.



Durable pneumatic brake with load sensing valve for driving comfort & safety

SPECIFICATIONS*

PERFORMANCE

Max. Speed 95 km / hr.
Max. Gradeability 25%

ENGINE

Model Perkins 135Ti
Type Four-Cylinder, in-line, turbo inter cooler
Bore x Stroke 100mm x 127mm
Max. Output 137 ps
Max. Torque 45 kgf.m
Displacement 3990 cc
Emission EURO IItz

CLUTCH

Type Single disc, dry type, diaphragm spring
Size $\phi 325 \times \phi 200$

TRANSMISSION

Type	6 Forward + 1 Reverse OD transmission, 2nd - 5th Synchronesh			
Ratios	1st	6.314	5th	1.00
	2nd	3.913	6th	0.788
	3rd	2.262	Reverse	5.874
	4th	1.393	Final Gear Ratio	5.871

AXLE

Front Reverse Elliot, "I" beam
Rear Whole banjo type

BRAKES

Service Drum brake (Dual circuits pneumatic brake)
Parking Central drum brake
Exhaust Exhaust brake

STEERING

Type Mechanical circular ball type with Power Steering

SUSPENSION

Type (Front & Rear) Semi - elliptic, laminated leaf springs, hydraulic double acting telescopic type shock absorbers on front & rear axes

TYRE

Size 7.50 R16/7.50 - 16
No. of Tires 7 including 1 spare tire

FUEL TANK

Capacity 120 Liters

ELECTRICAL SYSTEM

Battery 2 x 12 Volt, 100 AH
Generator 24 Volt

WEIGHT

Permissible Gross Vehicle Weight kg 10250
Kerb Weight kg 3030

DIMENSIONS

Wheelbase	mm	3800	Ground Clearance	mm	180
Overall Length	mm	6785	Cab to Rear Axle	mm	3137
Overall Width	mm	2100	Cab to End of Frame	mm	4950
Overall Height Approx.	mm	2390	Front Overhang	mm	1167
Tread Front	mm	1676	Rear Overhang	mm	1818
Tread Rear	mm	1615			

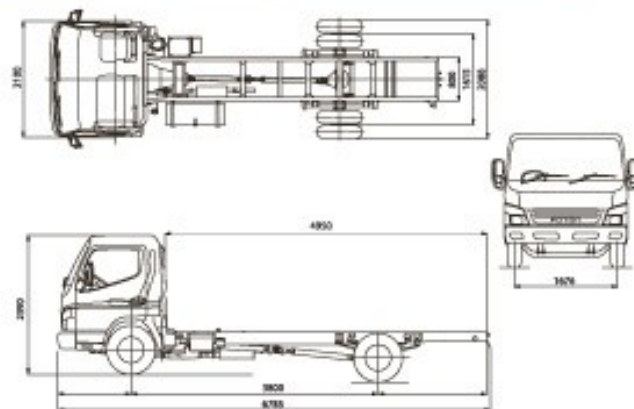

CAB

Tilt type with torsion bar, all steel welded construction

APPLICATIONS



Cargo



Trailer



Garbage Collector



Fire Fighting Truck



Cargo with Crane



Van



Dump Truck



Truck with Trailer



Authorized Distributor
MASTER MOTOR COMPANY
Marketing & Sales Offices

Karachi : 111-MASTER Lahore : 111-886-555
Islamabad : 5478158 Multan : 0322-8116283
Faisalabad : 0306-7328511

Dealer's Stamp