



**MASTER MOTOR**



**TRUCKING  
MADE BETTER**

**EVERY LOAD EVERY ROAD**



THE *Journey* BEGAN IN 1963



## ABOUT MASTER GROUP

Master Group of Industries; a story of heritage and legacy. We are one of the oldest and most trusted brands of Pakistan for over half a century. Master Group was established in 1963 and started its operations in the mattress industry, with a modern and realistic approach towards growth through innovative technology and manufacturing quality products. Since then, the group has expanded into the automotive, textile, furniture, engineering and renewable energy sectors. The group believes in developing long-term business relationships with both local and international stakeholders across industries. It strives for the progress and prosperity of Pakistan through leadership in industrialization, innovation, and corporate social responsibility.

Each member of the conglomerate employs cutting-edge transmutation methods in the production of goods that meet or exceed global benchmarks. We're now the most prominent business organization in Pakistan, and we've used that position of leadership to acquire our basic principles and continue expanding in a variety of ways that benefit the economy and create jobs.

# ABOUT US

Shacman (Shaanxi Automobile Group Co., Ltd.) is a prominent Chinese manufacturer of heavy-duty trucks and military vehicles, established in 1968 and headquartered in Xi'an. Master Motor has partnered with Shacman to introduce a curated line up in Pakistan, marking a significant advancement toward localized manufacturing.

With global partnership such as Cummins & WEICHAI, Shacman has a strong presence in over 140 countries and is renowned for its reliable, high-performance trucks. The company is also recognized for its innovation in new-energy and autonomous vehicle technologies.

**WEICHAI**



WEICHAI, one of the world's top diesel engine manufacturers, provides the power for Shacman trucks, delivering up to 380HP of surging power.



**HANDE AXLE**



The HANDE axle adopts cutting-edge technology and has the advantages of strong carrying capacity and higher torque performance.

**Fast**



FAST, the world's largest supplier by market share, supplies transmissions that balance economy and reliability.





# TRUCKING MADE BETTER

ROARING INTO PAKISTAN IN 2025

# L3000

Lorry Truck (RT) 240HP 4x2



Rough Weather, Tougher Truck: Unleash raw power built to thrive in Pakistan's heat, rain, and rugged terrain—backed by unshakeable durability that goes the distance, day after day.

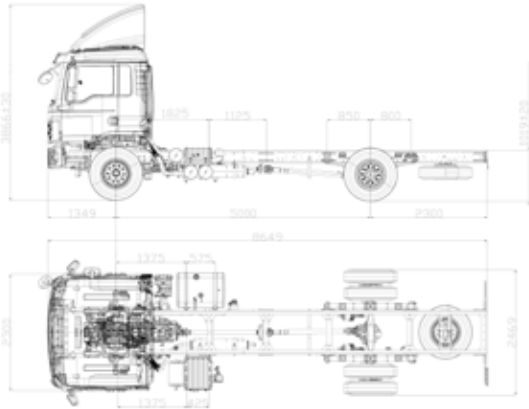

WEICHAH ENGINE

FAST TRANSMISSION

HANDE SINGLE AXLE

## PRODUCT SPECIFICATIONS

<b>Model</b>	SX11858K501R
<b>Drive type</b>	4x2
<b>Model</b>	Rigid Truck
<b>Complete kerb mass (kg)</b>	5,200
<b>GVW (kg)</b>	17,500
<b>Gradeability</b>	31%

<b>Dimensions</b>	
<b>Overall (L*W*H)</b>	8649x2469x(3866+30)
<b>Wheel base (mm)</b>	5,000
<b>Chassis Frame (mm)</b>	870x250(7+4)

<b>Engine</b>	
<b>Brand</b>	WEICHAH
<b>Type</b>	WP6.240E32 (Euro II)
<b>Displacement (L)</b>	6.49 L
<b>Power (kW/hp @rpm)</b>	176/240 @2300
<b>Torque (Nm @rpm)</b>	900 @1400-1600

<b>Transmission</b>	
<b>Type</b>	8JS85TM
<b>Gears</b>	1:9.651   2:6.463   3:4.318 4:3.193   5:2.235   6:1.497   7:1.000   8:0.739   R1:9.802   R2:2.270

<b>Clutch</b>	
<b>Type</b>	Diaphragm spring
<b>Diameter(mm/in)</b>	φ395 / 15.5"

<b>Brakes</b>	
<b>Type</b>	Drum
<b>Service brake</b>	Dual air brake with ABS
<b>Parking brake</b>	Power spring brake acting on front & rear wheel
<b>Auxiliary brake</b>	Exhaust brake

<b>Steering Wheel</b>	
<b>Steering</b>	Right-hand drive

<b>Suspension</b>	
<b>Front Suspension</b>	Multi- leaf springs
<b>Rear Suspension</b>	Multi- leaf springs

<b>Axles</b>	
<b>Front axle</b>	i-beam
<b>Rear axle</b>	Single Axle
<b>Gear ratio</b>	5.286

<b>Tires</b>	
<b>Type</b>	11.00R20
<b>Rim radius (in)</b>	8
<b>Numbers</b>	6+1

<b>Fuel Tank</b>	
<b>Tank capacity (L)</b>	300
<b>Material</b>	Aluminium Alloy

<b>Battery</b>	
<b>Type</b>	135Ah Maintenance-free battery (Manual Flip)

<b>Cab</b>	
<b>Type</b>	Standard Cab (Single Sleeper)

<b>Others</b>	
Air conditioner/Central lock (dual remote control)/Air suspension main seat/Sleek LED daytime running lights/Four point air suspension/Power windows/Roof side deflector	

\*Specifications are with normal manufacturing allowances & are subject to change without prior notice due to our on-going research & development program or to meet Local & Government requirements. Original product may vary from the one presented in this flyer.

# H3000S

Prime Mover 270HP 6x4

Charge ahead with unbeatable grit to crush every challenge. Engineered for epic excellence to unlock your path to unstoppable glory.

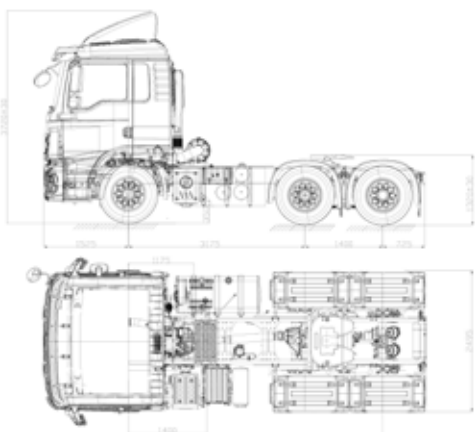

JOST FIFTH WHEEL



HANDE REAR AXLE



HANDE DOUBLE AXLE

## PRODUCT SPECIFICATIONS

Model	SX4595HL324R
Drive type	6x4
Model	Prime Mover
Complete kerb mass(kg)	7,900
GCW(kg)	58,500
Gradeability	22%

Dimensions	
Overall (L*W*H)	6825x2550x(3720±30)
Wheel base (mm)	3175+1400
Chassis Frame (mm)	850X270 (8+4)

Engine	
Brand	WEICHAJ
Type	WP7.270E31 (Euro II)
Displacement (L)	7.47 L
Power (kW/hp @rpm)	199/270 @2300
Torque (Nm @rpm)	1100 @1400-1600

Transmission	
Type	FAST 9JS135T-B
Gears (Hi-Low)	1:12.130   2:8.095   3:5.965   4:4.426   5:3.365   6:2.406   7:1.773   8:1.315   9:1.000   R1:12.681

Clutch	
Type	Diaphragm spring
Diameter(mm/in)	φ430/ 17"

Brakes	
Type	Drum
Service brake	Dual air brake
Parking brake	Power spring brake acting on front & rear wheel
Auxiliary brake	Exhaust brake

Steering Wheel	
Steering	Right-hand drive

Suspension	
Front Suspension	Multi- leaf springs
Rear Suspension	Multi- leaf springs

Axles	
Front axle	HANDE MAN Tech
Rear axle	HANDE MAN Tech Single Hub Reduction
Gear ratio	4.111 & 4.625

Tires	
Type	11.00R20
Rim radius(in)	8
Numbers	10+1

Fuel Tank	
Tank capacity (L)	600
Material	Aluminium Alloy

Battery	
Type	165Ah Maintenance-free battery (Manual flip)

Cab	
Type	Standard Cabin (Single Sleeper)

Others	
Air conditioning/Electric window shaker/Central lock (with remote control)/Air suspension main seat/Power Windows/Sleek LED Day time running lights/ Fifth wheel	

\*Specifications are with normal manufacturing allowances & are subject to change without prior notice due to our on-going research & development program or to meet Local & Government requirements. Original product may vary from the one presented in this flyer.

# H3000S

Prime Mover 380HP 6x4

Where style meets muscle, a towering titan with world-class presence—engineered for your fleet's image, backed by Master Motor's local parts and service network.

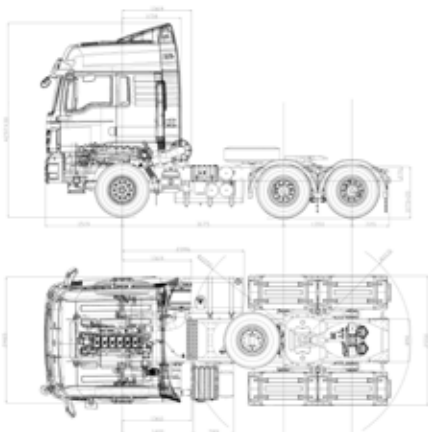

WEICHAH ENGINE



JOST FIFTH WHEEL



HANDE DOUBLE AXLE

## PRODUCT SPECIFICATIONS

Model	SX4595GT324R
Drive type	6x4
Model	Prime Mover
Complete kerb mass(kg)	8,500
GCW(kg)	58,500
Gradeability	18%

Dimensions	
Overall (L*W*H)	6769x2550x(4297±30)
Wheel base (mm)	3175+1350
Chassis Frame (mm)	850X270 (8+4)

Engine	
Brand	WEICHAH
Type	WP10.380E22 (Euro II)
Displacement (L)	9.726 L
Power (kW/hp @rpm)	280/380 @2200
Torque (Nm @rpm)	1600 @1200-1600

Transmission	
Type	FAST 12JSD200TA-B
Gears (Hi-Low)	1:12.098   2:9.518   3:7.313 4:5.711   5:4.462   6:3.476   7:2.712   8:2.133   9:1.639   10:1.280   11:1.000   12:0.779   R1:11.572   R2:2.594

Clutch	
Type	Diaphragm spring
Diameter (mm/in)	φ430/ 17"

Brakes	
Type	Drum
Service brake	Dual air brake with ABS
Parking brake	Power spring brake acting on front & rear wheel
Auxiliary brake	Exhaust brake

Steering Wheel	
Steering	Right-hand drive

Suspension	
Front Suspension	Multi- leaf springs
Rear Suspension	Multi- leaf springs

Axles	
Front axle	HANDE MAN Tech
Rear axle	HANDE MAN Tech Single Hub Reduction
Gear ratio	4.111 & 4.625

Tires	
Type	11.00R20
Rim radius (in)	8
Numbers	10+1

Fuel Tank	
Tank capacity (L)	600
Material	Aluminium Alloy

Battery	
Type	165Ah Maintenance-free battery (Manual flip)

Cab	
Type	Standard Cabin (Double Sleeper)

Others	
Air conditioning/Central lock (with remote control)/Air suspension main seat /Roofside deflector/Power windows/Sleek LED Day time running lights/Fifth wheel	

\*Specifications are with normal manufacturing allowances & are subject to change without prior notice due to our on-going research & development program or to meet Local & Government requirements. Original product may vary from the one presented in this flyer.

# H3000S

Dump Truck 380HP 6x4

Engineered for the heaviest loads with unmatched durability—trusted on Pakistan’s toughest routes, from mountain climbs to desert runs—delivering an unstoppable roar of power on every journey.

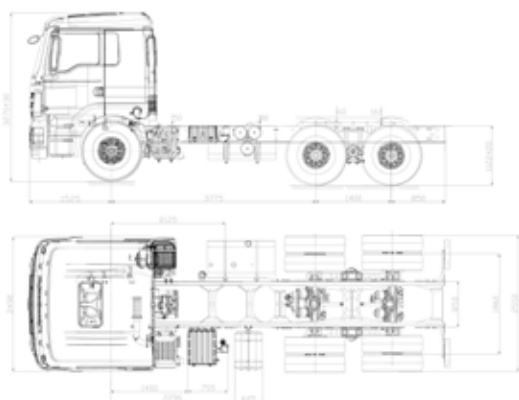

WEICHAH ENGINE

400 L FUEL TANK

HANDE DOUBLE AXLE

## PRODUCT SPECIFICATIONS

<b>Model</b>	<b>SX3255HT384R</b>
Drive type	6x4
Model	Dumper
Complete kerb mass(kg)	8,900
GVW(kg)	25,000
Gradeability	40%

<b>Dimensions</b>	
Overall (L*W*H)	7550x2550x (3270± 30)
Wheel base (mm)	3775+1400

<b>Engine</b>	
Brand	WEICHAH
Type	WP10.380E22 Euro II
Displacement (L)	9.726 L
Power (kW/hp @rpm)	280/380 @2200
Torque (Nm @rpm)	1600 @1200-1600

<b>Transmission</b>	
Type	FAST 10JSD180T+QH50
Gears (Hi-Low)	1:14.986   2:11.188   3:8.306   4:6.105   5:4.475   6:3.349   7:2.500   8:1.856   9:1.364   10:1.000   R1:15.113   R2:3.377

<b>Clutch</b>	
Type	Diaphragm spring
Diameter(mm/in)	φ430/ 17"

<b>Brakes</b>	
Type	Drum
Service brake	Dual air brake
Parking brake	Power spring brake acting on front & rear wheel
Auxiliary brake	Exhaust brake

<b>Steering Wheel</b>	
Steering	Right-hand drive

<b>Suspension</b>	
Front Suspension	Multi- leaf springs
Rear Suspension	Multi- leaf springs

<b>Axles</b>	
Front axle	HANDE MAN Tech
Rear axle	HANDE MAN Tech Double Drive Axle
Gear ratio	5.262 & 5.92

<b>Tires</b>	
Type	11.00R20   12.00R20
Rim radius (in)	8
Numbers	10+1

<b>Fuel Tank</b>	
Tank capacity (L)	400
Material	Aluminium Alloy

<b>Battery</b>	
Type	165Ah Maintenance-free battery (Manual flip)

<b>Cab</b>	
Type	Standard Cabin (Single Sleeper)

<b>Others</b>	
Air conditioner/Electric window shaker/ Air suspension main seat/Water tank protection /Power windows/Central lock (with remote control)/Sleek LED Day time running lights	

\*Specifications are with normal manufacturing allowances & are subject to change without prior notice due to our on-going research & development program or to meet Local & Government requirements. Original product may vary from the one presented in this flyer.

# H3000S

Dump Truck 380HP 8x4

Engineered for the heaviest loads with unmatched durability—trusted on Pakistan’s toughest routes, from mountain climbs to desert runs—delivering an unstoppable roar of power on every journey.

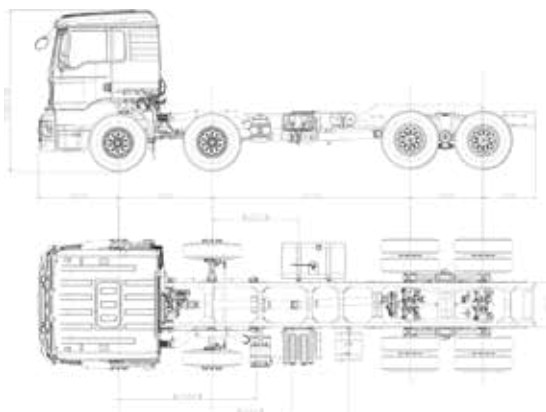

WEICHAH ENGINE

400 L FUEL TANK

HANDE DOUBLE AXLE

## PRODUCT SPECIFICATIONS

Model	SX3315HT386R
Drive type	8x4
Model	Dumper
Complete kerb mass(kg)	10,200
GVW(kg)	31,000
Gradeability	30%

Dimensions	
Overall (L*W*H)	9495x2495x (3300± 30)
Wheel base (mm)	1800+3775+1400

Engine	
Brand	WEICHAH
Type	WP10.380E22 Euro II
Displacement (L)	9.726 L
Power (kW/hp @rpm)	280/380 @2200
Torque (Nm @rpm)	1600 @1200-1600

Transmission	
Type	FAST 10JSD180T+QH50
Gears (Hi-Low)	1:14.986   2:11.188   3:8.306   4:6.105   5:4.475   6:3.349   7:2.500   8:1.856   9:1.364   10:1.000   R1:15.113   R2:3.377

Clutch	
Type	Diaphragm spring
Diameter(mm/in)	φ430/ 17"

Brakes	
Type	Drum
Service brake	Dual air brake
Parking brake	Power spring brake acting on front & rear wheel
Auxiliary brake	Exhaust brake

Steering Wheel	
Steering	Right-hand drive

Suspension	
Front Suspension	Multi- leaf springs
Rear Suspension	Multi- leaf springs

Axles	
Front axle	HANDE MAN Tech
Rear axle	HANDE MAN Tech Double Drive Axle
Gear ratio	5.26 & 5.92

Tires	
Type	11.00R20   12.00R20
Rim radius (in)	8
Numbers	12+1

Fuel Tank	
Tank capacity (L)	400
Material	Aluminium Alloy

Battery	
Type	165Ah Maintenance-free battery (Manual flip)

Cab	
Type	Standard Cabin (Single Sleeper)

Others	
Air conditioner/Electric window shaker/ Air suspension main seat/Water tank protection /Power windows/Central lock (with remote control)/Sleek LED Day time running lights	

\*Specifications are with normal manufacturing allowances & are subject to change without prior notice due to our on-going research & development program or to meet Local & Government requirements. Original product may vary from the one presented in this flyer.



111-MASTER (111 627 837) | [www.mmcl.com.pk](http://www.mmcl.com.pk) | [customer.relations@mmcl.com.pk](mailto:customer.relations@mmcl.com.pk)

